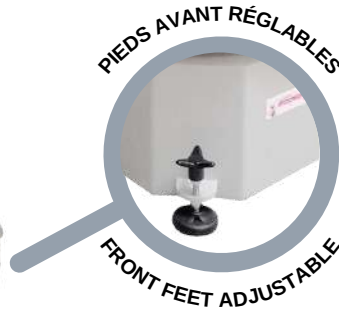

Photo non contractuelle / Non-contractual photo



## Gamme boulangerie

- Tableau de commande électromécanique
- 2 vitesses
- 2 minuteries
- 2 moteurs indépendants sauf PEB50MS
- Cuve et outils inox
- Grille de protection relevable
- Pieds avant réglables
- Changement automatique de la vitesse
- Transmission par courroies
- 400/50-60Hz/3

## PEB\*\*MS

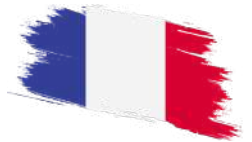

### Bakery range

- Electromechanical control panel
- 2 speeds
- 2 timers
- 2 independent motors expt PEB50MS
- Stainless steel bowl and tools
- Stainless steel raising safety grid
- Front feet adjustable
- Automatic change of operating speed
- Belt transmission
- 400/50-60Hz/3

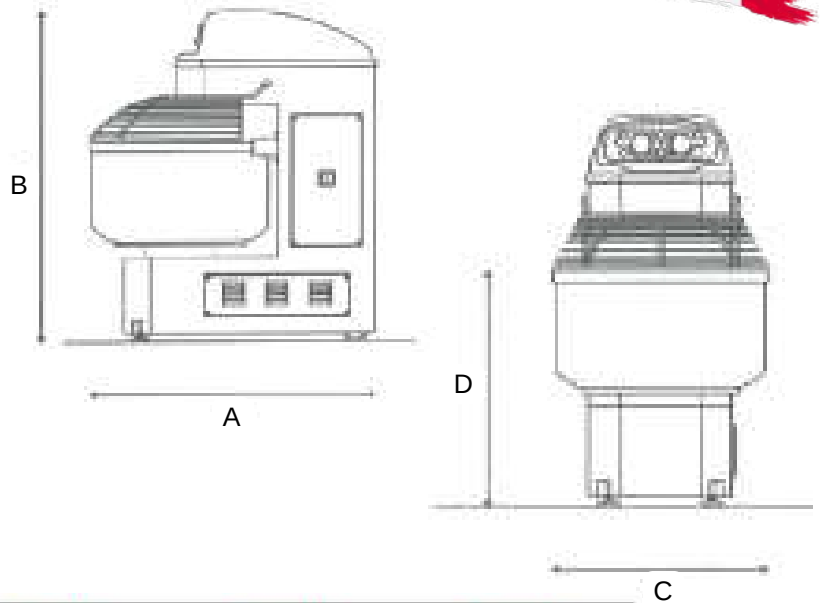

	PEB50MS (1 moteur / motor)	PEB60MS	PEB80MS	PEB100MS
<b>Capacité / Capacity</b>				
Cuve / Bowl (L)	70	100	130	160
Farine / Flour (Kg)*	30	40	53	66
Pâte / Dough (Kg)*	50	60	80	100
<b>Dimensions</b>				
A mm	1020	1180	1305	1305
B mm	1230	1312	1460	1460
C mm	550	630	730	730
D mm	-	800	830	850
<b>Poids / Weight</b>				
Kg	300	370	510	520
<b>Puissance moteur outil / Tool motor power</b>				
1 <sup>ère</sup> vitesse / 1st speed (kW)	1.5	1.5	3	3
2 <sup>ème</sup> vitesse / 2 <sup>nd</sup> speed (kW)	3	3	5.2	5.2
<b>Puissance moteur cuve / Bowl motor power</b> (kW)	-	0.55	0.75	0.75
<b>Options</b>	Modèle surélevé Raised model	Modèle surélevé Raised model Commandes digitales Digital control panel	Commandes digitales Digital control panel	Commandes digitales Digital control panel

\*suivant type de farine / depending on type of flour

Photo non contractuelle / Non-contractual photo

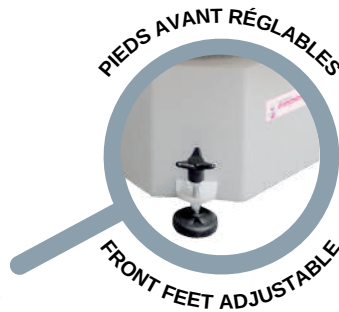

**Gamme boulangerie**

- 2 vitesses
- 2 moteurs indépendants
- Cuve et outils inox
- Grille de protection relevable
- Pieds avant réglables
- 2 minuteries
- Tableau de commande électromécanique
- Changement automatique de la vitesse
- Transmission par courroies
- 400/50-60Hz/3

**PEB\*MS**

**Bakery range**

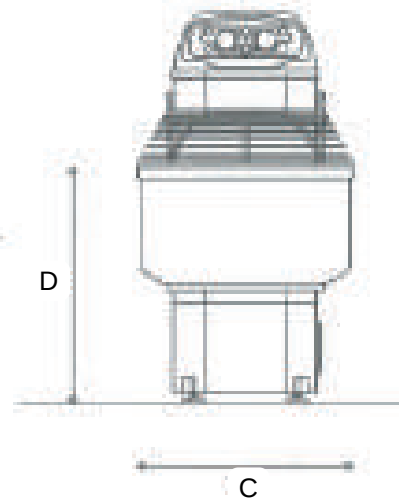
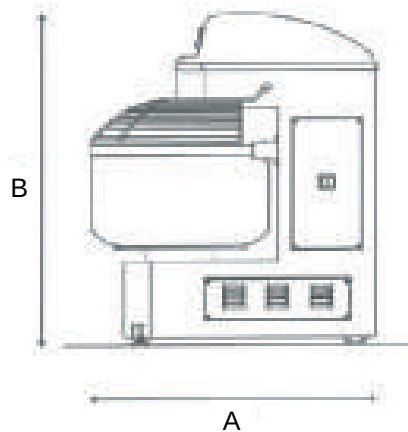
- 2 speeds
- 2 independent motors
- Stainless steel bowl and tools
- Stainless steel raising safety grid
- Front feet adjustable
- 2 timers
- Electromechanical control panel
- Automatic change of operating speed
- Belt transmission
- 400/50-60Hz/3



	PEB130MS	PEB160MS	PEB200MS	PEB250MS
<b>Capacité / Capacity</b>				
Cuve / Bowl (L)	200	250	290	390
Farine / Flour (Kg)*	86	106	133	166
Pâte / Dough (Kg)*	130	160	200	250
<b>Dimensions</b>				
A mm	1355	1440	1490	1580
B mm	1460	1560	1560	1560
C mm	830	930	930	1030
D mm	870	870	910	950
<b>Poids / Weight</b>				
Kg	580	790	830	870
<b>Puissance moteur outil / Tool motor power</b>				
1 <sup>ère</sup> vitesse / 1st speed (kW)	3	4.5	6.5	6.5
2 <sup>ème</sup> vitesse / 2 <sup>nd</sup> speed (kW)	5.2	7.8	11	11
<b>Puissance moteur cuve / Bowl motor power (kW)</b>	0.75	1.1	1.1	1.1
<b>Options</b>	Commandes digitales Digital control panel	Commandes digitales Digital control panel	Commandes digitales Digital control panel	Commandes digitales Digital control panel

\*suivant type de farine / depending on type of flour