

Corps de machine inox

Trémie inox 40 kg (50 litres)
Grammage selon modèle
Chargement des pâtons par trémie inox
Tapis de réception feutre
Puissance : 1.5 kW
230/400/50-60Hz/3
Poids net : 570 kg

Options :
Trémie 70 kg (80 L)
Trémie 80 kg (100 L)
Trémie 100 kg (150 L)
Trémie 150 kg (200 L)

PB*I

Stainless steel frame

Stainless steel hopper 40 kg (50 liters)
Dough piece feeding by stainless steel hopper
Outgoing belt in felt
Power : 1.5 kW
230/400/50-60Hz/3
Net weight : 570 kg

Options :
Hopper 70 kg (80 L)
Hopper 80 kg (100 L)
Hopper 100 kg (150 L)
Hopper 150 kg (200 L)

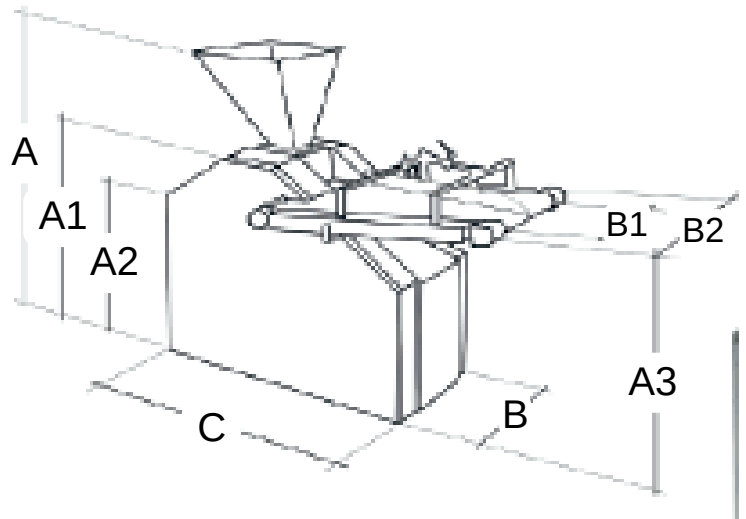

	PB110I	PB120I	PB135I	PB160MM	PB180I
Ø du piston / Piston Ø mm	110	120	135	160	180
Poids des pâtons / Dough weight piece gr	60 - 600	100 - 1000	140 - 1400	450 - 2000	500 - 2500
Dimensions					
A mm	1590				
A1 mm	1110				
A2 mm	902				
A3 mm	1067				
B mm	800				
B1 mm	480				
B2 mm	650				
C mm	1240				
Production horaire / Hourly production Pièces / Pieces	De 1080 à 2400				