

BT40B-D

Digital multi speed system

4 pre-programmed speeds - 99 programs

Digital control panel

Timer

Stainless steel bowl and tools

Bowl lifting by lever

Compensation cylinder for slowing down the lowering of the bowl

Spout on grid

Liftable safety grid

Food-grade plastic cover on the safety grid

Adjustable level by anti-vibration pads

Fixed castors

Safety switch of bowl detection

Driven by belts directly attached to the planetary

Notched belts

400/50-60Hz/3

Option :

Motorized bowl lifting

Additional equipments

Variateur de vitesse digital

4 vitesses pré-programmées - 99 programmes

Tableau de commande digital

Minuterie

Cuve et outils inox

Levage de cuve par levier

Vérin de compensation pour freiner l'abaisse de cuve

Bec verseur

Grille de sécurité relevable

Plexi de protection sur grille

Mise à niveau réglable par patins anti-vibrations

Roulettes fixes

Sécurité de présence de cuve

Entraînement en prise directe sur le planétaire

Courroies crantées

400/50-60Hz/3

Option :

Levage de cuve motorisé

Equipements de réduction

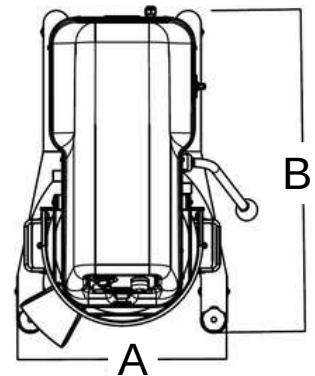
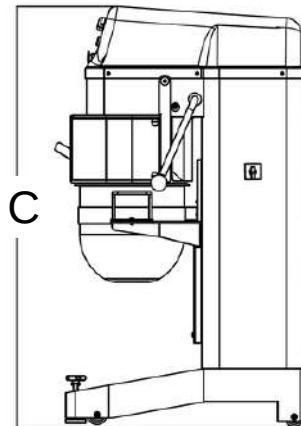

	BT40B-D
Capacité de la cuve / Bowl capacity	
Litres	40
Dimensions	
A mm	645
B mm	905
C mm	1530
Poids / Weight	
Kg	220
Puissance / Power	
kW	2.2
Options	Equipement de réduction 20 litres 20 litre additional equipment