

PExMC-TF

Gamme standard

- 2 vitesses
- Cuve et outils inox
- Tête et cuve fixes
- Grille de protection relevable
- Pieds réglables
- Minuterie
- Tableau de commande électromécanique
- Transmission par chaînes
- 400/50Hz/3

- Options :
- Roulettes dont 2 avec frein
 - Voltage : 1 vitesse (monophasé)

Standard range

- 2 speeds
- Stainless steel bowl and tools
- Fixed head and bowl
- Stainless steel raising safety grid
- Adjustable feet
- Timer
- Electromechanical control panel
- Chain transmission
- 400/50Hz/3

- Options :
- Castors, 2 with brake
 - Voltage : 1 speed (single phase)

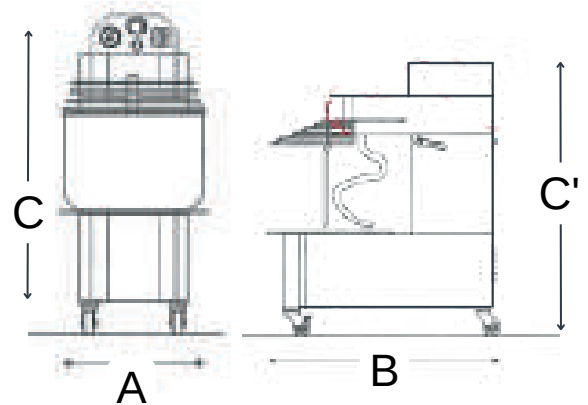

	PE12MC-TF	PE18MC-TF	PE25MC-TF	PE38MC-TF	PE44MC-TF	PE60MC-TF
Capacité / Capacity						
Cuve / Bowl (L)	15	20	33	40	50	75
Farine / Flour* (kg)	8	9	14	17	22	32
Pâte / Dough* (kg)	12	18	25	38	44	60
Dimensions						
A mm	350	410	430	480	550	585
B mm	675	715	770	820	878	1050
C mm	690	820	900	900	900	1210
C' mm (avec roulettes / with castors)	745	875	955	955	955	-
Poids / Weight						
Kg	60	70	95	110	120	226
Puissance / Power						
1 ^{ère} vitesse / 1st speed	0.6	0.6	1	1.5	1.5	2.6
2 ^{ème} vitesse / 2 nd speed	0.8	0.8	1.4	2.2	2.2	3.4
Voltage	400/50-60Hz/3	400/50-60Hz/3	400/50-60Hz/3	400/50-60Hz/3	400/50-60Hz/3	400/50-60Hz/3

*suivant type de farine / depending on type of flour